

# Ionic Mist Humidifier

Humidifies • Purifies • Refreshes

by **Advanced**   
*PureLiving*  
ENVIRO-FRIENDLY TECHNOLOGY



---

## **OWNER'S MANUAL**

---

# IMPORTANT SAFETY INSTRUCTIONS:

Please exercise caution when using the Ionic Mist or any other electrical device! This manual describes the safety precautions which should be observed in relation to your humidifier. Please review carefully **BEFORE** using this product.



RATED  
VOLTAGE

The voltage rating for humidifiers sold in the USA, Japan and Canada is AC100-120V, 50/60Hz and in Europe is AC 230V, 50Hz. Using the wrong current may result in unit damage, electrical shock or fire.



DO NOT  
DISMANTLE

Do NOT attempt to dismantle, repair or modify this device on your own. Doing so could result in electrical shock or damage to the unit. In the event of malfunction, contact an authorized maintenance facility.



AVOID DIRECT  
SUNLIGHT

Do NOT place the unit in direct sunlight or near lit fireplaces, furnaces, ovens or other high temperature objects. Doing so can damage the humidifier and may pose a fire hazard. Avoid operating the unit when the air temperature is below 32° F/0° C or exceeds 113° F/45° C.



DO NOT  
TOUCH

The inner nebulizer (item #9 under Parts & Supplies below) is a sophisticated ultrasonic transducer and is highly sensitive. Do not touch it with bare fingers or scrape with metal tools. Doing so can significantly reduce the unit's misting output.



NO TAP  
WATER

Do not use hot water or unfiltered tap water in your humidifier. Use only purified or distilled water to prevent clogging and damage to the misting components.



UNPLUG

Unplug your Ionic Mist Humidifier whenever you clean, service or move the unit or when you will not be using your humidifier for an extended period of time.

## PARTS:

1. Water Tank
2. Mist Outlet
3. Negative Ion/Activated Oxygen On/Off Button
4. Blue Light Illuminator
5. Mist On/Off Switch
6. Negative Ion/Activated Oxygen Outlet
7. Negative Ion/Activated Oxygen Indicator
8. Water-Position Sensor
9. Inner Nebulizer/Ultrasonic Transducer
10. Water-Storage Tank

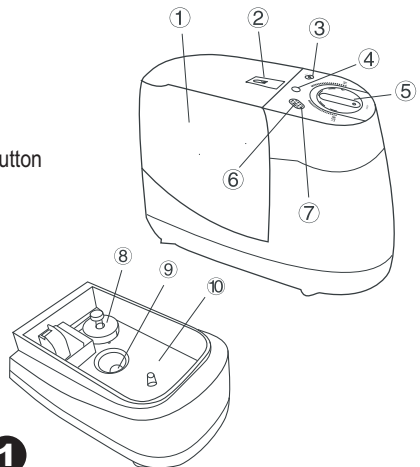

1

## KEY FEATURES:

- Releases negative ions that clean and freshen the air as it humidifies!
- Quiet, energy-efficient ultrasonic vibration misting technology.
- Portable and powerful compact design humidifies over 200 Sq. Ft.
- Large misting reservoir provides over 8 hours of refreshing, moist air.
- Dual speed operation, with intuitive controls and built-in night light

## OPERATING INSTRUCTIONS:

### Fill Water Tank

Handle the water tank firmly when removing it from the base (See Photo). Turn upside down and unscrew filling cap. Fill tank with pure water only. Return tank to base and replace the cap firmly.

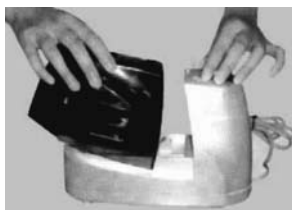

### Turn Unit On

Plug into a power outlet. Turn Mist Switch to LOW level clockwise then the blue light is on, the unit begins misting operation. The mist amount can be set arbitrarily according to the humidity status in the room. The mist amount will be increased by turning Mist Switch clockwise and will be reduced by the opposite direction.

- The unit should be placed on flat, level surface and do not move it around when operating to prevent the overflow of water inside tank.
- Aim mist outlet away from furniture and walls.
- The humidifier will run up to 12 hours on Low level and 8 hours on High level.

### Turn Unit Off After Use

This product has an auto shut off feature that cuts off misting after the tank runs out of water. However, because other functions of the unit will continue to operate, we encourage you to manually still turn the humidifier off immediately after tank runs out of water (Switch to OFF).

### Negative Ion & Activated Oxygen Output

The humidifier has independent negative ion and activated oxygen (ozone) output functions. In seasons that do not require humidified ambience, it can be used as an independent air purifier. To start the air purification, press the Negative Ion and Activated Oxygen On/Off Button. The indicator will illuminate at this time. To stop the function, press the button again. The maximum activated oxygen output is limited to less than 0.04 parts per million (ppm) which provides effective air purification capability but falls well within Federal safety standards.

# Ionic Mist Humidifier

Humidifies • Purifies • Refreshes

by **Advanced**   
**PureLiving**  
ENVIRO-FRIENDLY TECHNOLOGY

## CARE AND MAINTENANCE:

**Caution! Always unplug the humidifier before maintenance!**

### When to Clean the Humidifier

- Every third day during summer seasons.
- Before storing or after long time of storage.

### Cleaning Steps

1. Before you begin cleaning your humidifier, first remove tank from base and empty it.
2. Use the brush provided within box to clean off scale and debris from nebulizer and water sensor. Do not use tools that have metal parts to scrape nebulizer and sensor.
3. Do not use detergent to clean any water containing parts of the machine. Detergent dissolved in the water can reduce misting efficiency.
4. The nebulizer (ultrasonic transducer) is most sensitive and precision part in this machine. It is important to keep this part clean and correctly serviced.
5. When sanitizing the water tank, a mild bleach and water solution is recommended. Never use detergent. Exterior can be wiped with a damp cloth when unit is off. Remember not to allow the cleaning water run into electrical controlling parts.
6. The water-position sensor inside of the tank is an important component for stop misting automatically, needs frequent taking off for cleaning and maintenance. Please do not use too much force when opening the cover fixed on the top of the water-position sensor pole, remove the sensor and clean it with water, and fix it correctly.

### Storing the Humidifier

- Be sure all parts are completely dry.
- Leave the tank's fill cap loose to prevent the cap sticking to its gasket.

## TROUBLESHOOTING:

Problem	Cause	Suggested Solution
No Power (LED is OFF)	<ul style="list-style-type: none"> <li>Unit not plugged in.</li> <li>No power at outlet.</li> </ul>	<ul style="list-style-type: none"> <li>Plug in unit.</li> <li>Check circuits, fuses, and test outlet with a tester.</li> </ul>
No Mist (LED is OFF)	<ul style="list-style-type: none"> <li>No water in tank.</li> <li>Inoperative fan.</li> <li>Inoperative components.</li> </ul>	<ul style="list-style-type: none"> <li>Fill tank with water</li> <li>Contact us for service</li> <li>Contact us for service</li> </ul>
No Mist When Water Tank is Full.	<ul style="list-style-type: none"> <li>Mist setting is on low.</li> <li>Unit is not level.</li> <li>Scale on nebulizer or sensor.</li> <li>Detergent used in water tank.</li> <li>Nebulizer may be damaged.</li> </ul>	<ul style="list-style-type: none"> <li>Use a higher setting</li> <li>Place unit on a level surface</li> <li>Clean nebulizer and sensor with brush attached and fill with pure water.</li> <li>Rinse the unit thoroughly with clean water.</li> <li>Send to service center</li> </ul>
White Powder Accumulation	<ul style="list-style-type: none"> <li>High mineral-tap water or hard water condition</li> </ul>	<ul style="list-style-type: none"> <li>Use distilled water or at least ½ distilled and ½ tap water.</li> </ul>

## AFTER SALES SERVICE:

In case of malfunction, please review the troubleshooting steps outlined in the section above. If the problem remains unresolved after taking the suggested applicable actions, please email Real Spirit USA, Inc. at [info@RealSpiritUSA.com](mailto:info@RealSpiritUSA.com) or telephone us at **(818) 698-2088**.

If you elect to email us please be sure to include the name of the product, the date and location of purchase, e.g., store name, internet site, etc.; the nature of the problem along with your name and phone number so we may contact you. If you elect to phone us, please have this same information readily available when placing your call.

## SPECIFICATIONS:

Applicable Area	Power Levels	Ion Output	Mist Capacity	Activated Oxygen Emission	Voltage Supply	Power Rating
215 sq ft	2	10,000/cm <sup>3</sup>	75ml/h(±10%)	<0.04 ppm	AC 100-120-60Hz	30 W

## DIMENSIONS:

Length	Height	Width	Weight
9.5 inches	6.3 inches	4.4 inches	3 lbs, 6 oz.

Notes: sq ft: square feet | cm<sup>3</sup>: cubic meters | ml/h: milliliters per hour | ppm: parts per million | W: watts

# Ionic Mist Humidifier

## LIMITED WARRANTY

<b>PRODUCT INFORMATION:</b>	<b>Ionic•Mist Humidifier</b>	Date of Purchase	
		Warranty Period	One year from the date of purchase
<b>CUSTOMER INFORMATION:</b>	Name:		
	Address:		
	Phone #:		
<b>PLACE OF PURCHASE:</b>	Name & Address of Store or Website URL As Applicable		

- (1) This product passes strict tests prior to leaving the factory. Customers could, within one year from the date of purchase, enjoy free repair or replacement of parts if it is checked by our company that malfunction or damage to the device and/or parts occurred under normal running condition.
- (2) Guarantee does not cover damages that are attributed to self dismantling and assembling, unauthorized operation not found in the instructions, random change of power source and/or voltage, artificial causes and natural disasters.
- (3) The date(s) on this guarantee and the purchase invoice will be used to determine the validity of one year free maintenance.

*Produced and distributed by:*



Real Spirit USA, Inc. • 9447 De Soto Ave • Chatsworth, CA 91311  
Phone 818.698.2088 • Fax 818.698.2090  
[www.AdvancedPureLiving.com](http://www.AdvancedPureLiving.com) • [info@RealSpiritUSA.com](mailto:info@RealSpiritUSA.com)

*Manufactured in China*